

SK-RMP ULTRA 959

Ring Main Pump for Instantaneous GAS HWS

With dedicated return line

Installation & startup guide

NOTES:

- Must use 3/4" recirculation line piping or tubing.
- Install at the furthest extreme from your hot water heater or in the insulated return line. (for easy access, could be under the sink at the furthest from the water heater)
- The return line should be connected to the ringmain return port (if fitted), or the cold water inlet line (tee fitting required)
- For Multiple branched supply lines installations, a recirculation line should be installed for each branch.
- The pump must always be installed below the water level of water heater so that the pump flow is always upward or horizontal, not downward.
Do not mount the pump above the water heater. (also see Fig. 3)
- Your SK-RMP ULTRA 959 incorporates a shut-off valve and check valve in the brass housing, eliminating the need to add these components.
- **Remove the 3/4" union fittings before soldering to avoid damaging the internal valves.**



Installation Procedure:

1. Shut off water
2. Drain the plumbing lines by opening taps
3. Drain the water heater to the ringmain port if fitted, or to the bottom if using the cold supply.
4. Tee into the hot supply line as close as possible to the last tap, connect the pump, and run the return line back to the water heater.
5. Install the pump and other components as required. (see Recirculation Line diagram, and Pump Mounting Positions – Fig. 3)
6. The Ultra 959 model may installed without disassembling the pump. However, it is recommended that the motor section be disassembled from the pump housing by removing the two pump housing screws so that the system may be flushed.

Shut-off valve allows isolation for pump service.

Hose Bib allows venting of air from system at startup.

Auto Air Vent (if fitted) allows continuous venting of air bubbles that may intrude into any hot water recirculating system.

7. **Installing the pump:** Remove 3/4" copper tails, union nuts and motor from the pump housing. Attach the copper tails and union nuts to the return pipe and solder the tails on. **DO NOT** solder the 3/4" tails while connected to the pump housing as the pump housing contains plastic components which will melt.
8. Fit pump housing without motor attached. **Close the shut-off valve** on the inlet side of the pump and turn the water supply back on.

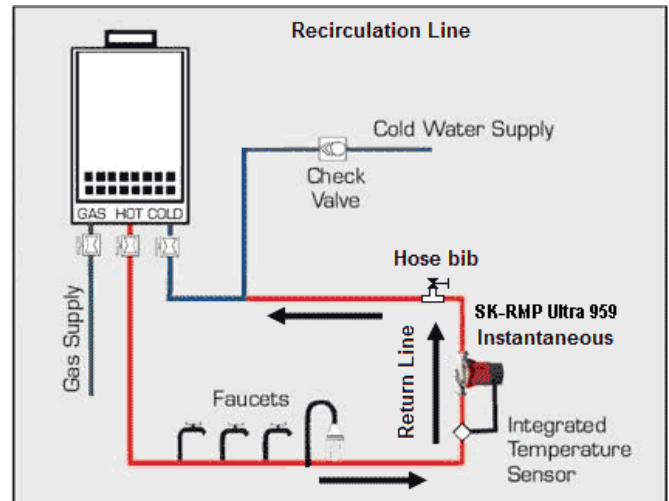

1300 552 976

website: www.skylineenergy.com.au

email: info@skylineenergy.com.au

Pump Mounting Positions fig. 3

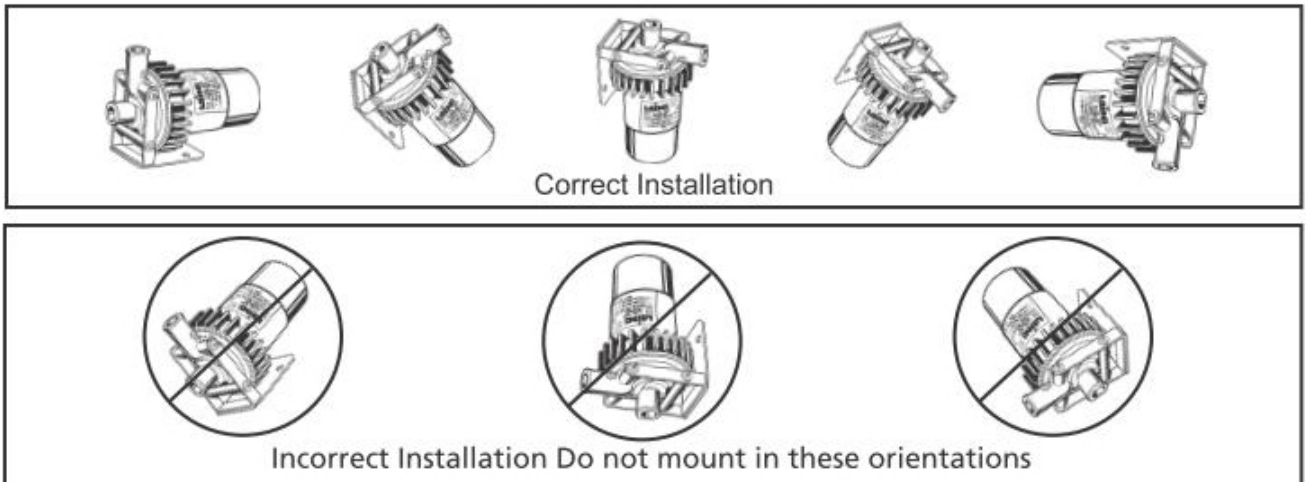

9. **Flush the system of debris.** Before reattaching the pump motor, open the shut-off valve on the inlet side of the pump housing and let water flow through the housing. (have bucket ready!) Let water run long enough to clear all sand, solder pellets, plumbers tape flakes etc. from the lines. Close the inlet shut-off valve when finished.
10. **Connect the pump motor to the housing.** Make sure the rubber O-ring is in place in the housing and the top housing screws are firmly in place and tightened. **Reopen the shutoff valves and let water flood the pump housing.**
11. **Purge air from the supply line.** Turn on the tap or shower farthest from the water heater. Open the line until you get a good, steady stream of water without sputter or evidence of air.
12. **Purge air from the return line.** Connect the pump to the electrical supply. With the pump running, open the hose bib and let water run until the pump is running quietly and there is no sputtering or other evidence of air coming from the hose bib. Close the hose bib. Your system is now in operation. Allow a few minutes for instant hot water to recirculate to all of your outlets.
13. If desired, set your timer in accordance with the Timer Controlled Operation Instructions below.

SAFETY PRECAUTION: Remove the handle from the hose bib to prevent a small child from mistaking it for a cold water tap.

INSULATING: Adequately insulating the entire ring main is strongly recommended, and maybe mandatory in some states.

Timer Controlled Operation Instructions:

The timer may be programmed to allow the pump to operate only during the hours desired. (example: "ON" from 6:00am to 9:00pm, and "OFF" from 9:00pm to 6:00am) as follows:

- Open timer cover and rotate the dial clockwise until the correct time is aligned with the pointer on the right side (3 o'clock position)
- Automatic operation: PULL the tabs upward on timer for the desired operating periods. Note: may be set for multiple time periods.
- Slide the switch bar to 'timer'.

The timer mode programmed to operate only when hot water is most frequently required, provides the most cost-effective method of operation. (It will still only operate when the built-in thermostat senses that hotter water is required.

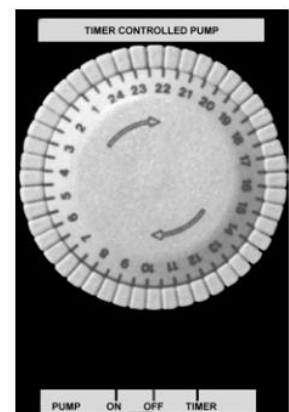

30 Min. Tabs

1300 552 976

website: www.skylineenergy.com.au

email: info@skylineenergy.com.au

Engineered for life



AC Canned Spherical Motor Centrifugal Pumps

Applications

Specifically designed for the following use:

- Recirc System for Tankless Water Heaters

Specifications

Pump:

- Max Capacities: 6 GPM
- Max Head: 24'
- Pipe Connections:
3/4" Union Connections
- Maximum Working Pressure: 150 PSI
- Maximum Temperature: 230° F
- Rotation: counter clockwise when viewed from the motor end
- Timer and Temperature Controlled

Motor:

- Canned Spherical Type Motor
- 909 - 115 Volt 98 Watts 60 Hz, 3450 RPM
- Automatic Overload Protection
- 959 - 230 Volt 80 Watts 50 Hz, 2850 RPM

Features

Compact Design:

Close coupled, space saving design provides easy installation.

Mounting:

Pump can be mounted horizontally or vertically with motor end down.

Construction:

ASTM lead free bronze construction.

Ceramic Bearing Ball and Carbon Bearing Cap:

High density ceramic bearing ball and graphite impeller bearing cap designed for high efficiency and long life.

Impeller:

Highly efficient and dynamically balanced with carbon bearing for smooth ultra quiet operation.

Casing:

Casing is lead free bronze construction.

Mechanical Seal:

Unique patented design has no mechanical seal which is a potential leak path.

Motor:

Patented spherical motor pump design is ultra quiet and is designed for continuous operation. All ratings are within working limits of the motor.

Noise level:

Whisper quiet, less than 30 db

Weight:

Lightweight construction weighs less than 6lbs.

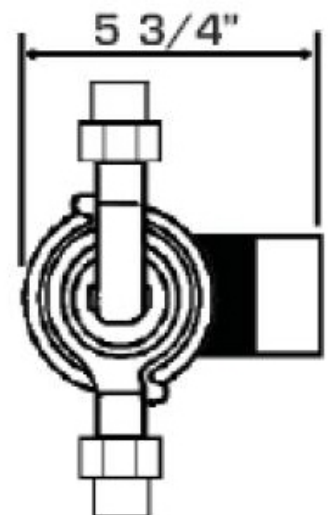
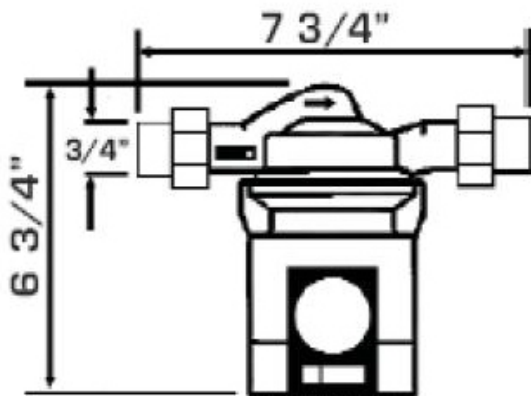

1300 552 976

website: www.skylineenergy.com.au

email: info@skylineenergy.com.au